



EverGuard™

Exterior Frame Products

See back for details.

The EverGuard* Advantage

Premium Performance With Competitive Pricing!

EverMark has achieved the best of both worlds with EverGuard frame components. Competitive pricing along with maintenance free components provides superior structure and stability for exterior door units. Offered in common widths and lengths, EverGuard jambs and mulls are available with straight end-cuts, or fabricated to your specifications. EverGuard jambs can also be milled, drilled, cut and nailed like standard wood jambs.

A Complete Line of Exterior Frame Components

- EverGuard™ Jambs
- EverGuard™ Mulls
- EverGuard™ Trim

CHOOSE FROM TWO DESIGN OPTIONS

▶ EVERGUARD with “EndSeal”

Provides jamb, mull bottom and brickmould with long lasting protection from water and insect damage by sealing bottom end-grain with durable moisture resistant coating.

OR

▶ EVERGUARD DELUXE* with PVC Bottom Block

Constructed with a 2” bottom block of PVC, the Everguard Deluxe* option provides premium protection that is guaranteed to forever eliminate moisture wickage through the bottom of the jamb- the No.1 cause of frame failure.

▶ Both Options come standard with a PVC Cap

Bonded with a high-quality, exterior grade adhesive, this PVC cap becomes an integral part of every jamb, mull post and piece of brickmould. Dent resistant, scratch resistant and impervious to rot - The 1/8” PVC cap is glued directly to the wood to provide long lasting stability and protection. The PVC is colored 100% throughout, making scratches much harder to see that don't require touch-up.

***patent pending**

SEE BACK FOR PRODUCT AND WARRANTY DETAILS



EverGuard™ Exterior Frame Products

EverGuard® exterior frame products provide a solution to moisture wicking and the resultant frame rot, insect infestation and costly call-backs. Beautifully crafted, double-primed components with a low-maintenance, dent and scratch resistant PVC cap provides the workability and warmth of wood while providing cost-effective protection. A wide array of sizes and options gives you flexibility and control — from inventory to installation.

EverGuard™ Jamb

- Unique exterior door jamb combining quality double-primed, fingerjoint wood with a PVC cap which is impervious to rot.
- PVC cap is bonded to jamb with a high-quality, exterior grade adhesive.
- Frame sizes available
Nominal sizes
- Machining options include head and sill dado, hinge prep mortising, strike and deadbolt preps & pilot holes.
- Optional accessories include pre-installed security strike plate, hinges (US2-D, US3/4, primed, US4 and many others) and weatherstripping (compression or magnetic, both in beige or bronze).

WIDTHS			HEIGHTS	
4-9/16"	5-1/4"	6-9/16"	6'8"	8'0"

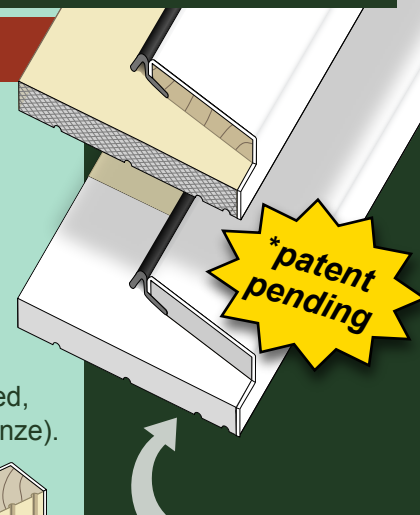

Choose from optional "EndSeal" or EverGuard Deluxe* with a 2" solid PVC bottom block to provide frames with long lasting protection.

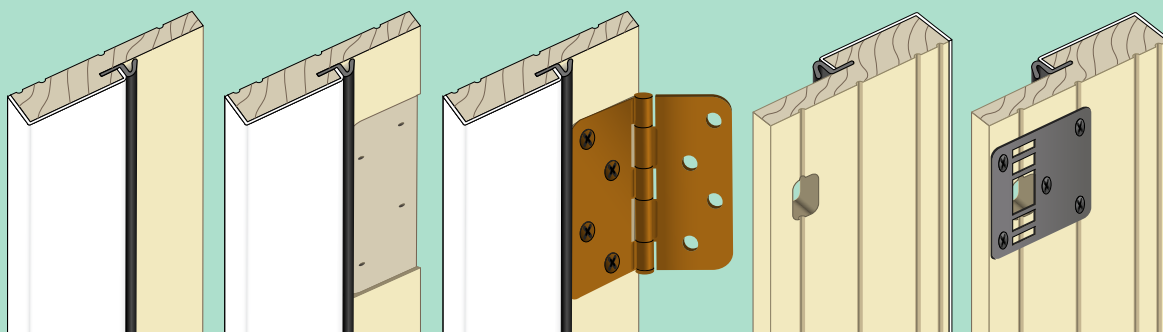

EverGuard™ Mulls

- Attractive, primed with a rot-free PVC cap that will not warp, check, split or wick moisture. Like EverGuard™ jambs, mullions are available with factory-applied hinges and several weatherstripping options.
- Mull sizes available:
Nominal sizes.

HEIGHTS	
6'8"	8'0"

- Standard: 1" x 2" x 4-3/8"
- Fat Boy: 1-1/2" x 2-1/2" x 4-3/8"

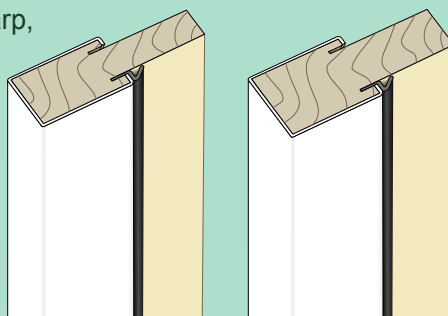

EverGuard™ Trim

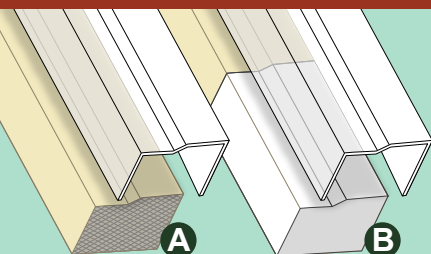

- Beautifully moulded brickmould with a bonded, 1/8" PVC cap to complement EverGuard™ Jamb and Mulls.
- Available with optional "EndSeal" **A** and as EverGuard Deluxe* with a bottom block of solid PVC **B**.
- Standard brickmould profiles available. Miter cut and available in all lengths.

FOR ORDERING INFORMATION CONTACT:

EverMark, LLC
1050 Northbrook Parkway
Suwanee, GA 30024
www.evermark-LNL.com

678-455-5188
(PHONE)

678-455-5190
(FAX)

OR EMAIL US:
emsales@evermark-LNL.com

The EverGuard™ Limited Lifetime Warranty

EverMark, LLC warrants their EverGuard™ exterior door frame products against degradation of the cellular vinyl profiles for as long as the original purchaser owns the EverGuard™ product. Should degeneration occur, rendering the jamb unable to support a hinge or sill, EverMark, LLC will replace the jamb without cost to the consumer for parts. Proof of purchase is required. This warranty applies to EverGuard™ products used in residential construction and to the original purchaser only, for as long as the original purchaser owns the EverGuard™ Product. This warranty does not cover defects in the finish or damage caused by improper painting, caulking or installation. This warranty is void if product is damaged through improper or unreasonable use. This warranty is void if any portion of the vinyl profile has been removed. EverGuard™ products are not covered in warranty if not properly maintained. Storm door installations, associated with our product, require sufficient ventilation to eliminate excessive heat build-up in the airspace between both doors. Failure to comply with this requirement voids this warranty.

Please note: It is a requirement of this warranty that the customer keeps and provides all invoices, receipts, and other relevant documents received at the time of purchase or for the maintenance of the door system and its components. For optimum performance, EverGuard™ products should be painted within 60 days of installation.

†This Product incorporates the patented FRAMESAVER® technology, under license from Endura Products, Inc., of Colfax, NC, and may be covered by one or more of the following U.S. Patent Nos. 5,661,943; 5,873,209; 5,950,391; 6,122,882; 6,425,222; 6,446,410; 7,100,339 and foreign equivalent patents.